

车槽

切断

铣槽

插削

仿形铣削

铰削



**新产品**

**NEW**

**铣刀类型 932**

- 9 个刀刃
- 切削效率高于 50%

**Milling insert Type 932**

- 9 cutting edges
- 50% more cutting efficiency

HORN-卓越于技术  
HORN - EXCELLENCE IN TECHNOLOGY



# 铣刀类型 932

除了具有 3 个和 6 个刀刃的铣削刀片外，并可提供具有 9 个刀刃的铣削刀片。

切削宽度从 2 毫米到最大 4 毫米。我们的产品采用可靠的基材以及硬质合金涂层 AS45。

具有 9 个刀刃的新刀片可与所有类型的铣刀柄 M332 配合使用。

## Milling insert Type 932

In addition to milling inserts with 3 and 6 cutting edges an insert with 9 cutting edges is available from stock.

The cutting widths are from 2 mm up to 4 mm. We built on a proven seating as well as the available carbide grade AS45. The new insert with 9-cutting edges is for use with all types of milling shank M332.



# 槽铣削 ( 圆弧插补铣削 )

## GROOVE MILLING by circular interpolation



刀片型号  
INSERT Type

# 932

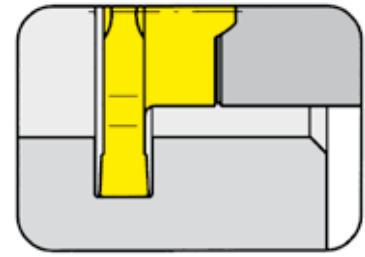

切槽深度可达	Depth of groove up to	8.3 mm
槽宽	Width of groove	2.0 - 4.0 mm
切削刃Ø	Cutting edge Ø	Ds 31.7 mm

配合 铣刀杆  
for use with Milling shank

型号 M332  
Type

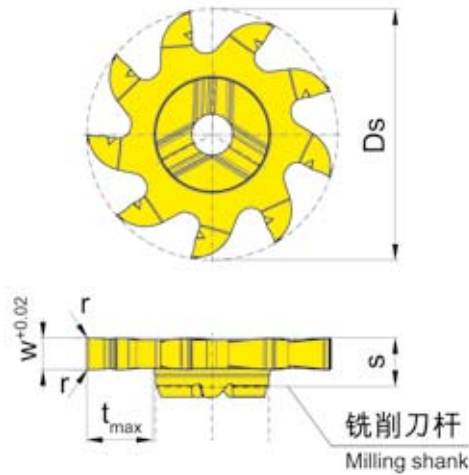

图示=右手型  
Picture = right hand cutting version

产品型号 Part number	w	r	s	t <sub>max</sub>	Ds	硬质合金牌号 Carbide grades	
						MG12	AS45
932.0200.00	2.0						▲
932.0250.00	2.5						▲
932.0300.00	3.0	0.2	6.1	8.3	31.7		▲
932.0400.00	4.0						▲
						P	•
						M	•
						K	•
						N	○
						S	•
						H	

▲ 库存 / on stock    Δ 4周 / 4 weeks  
 • 主要应用 / main recommendation  
 ○ 可选推荐 / alternative recommendation  
 ■ 无涂层牌号 / uncoated grades  
 ■ 涂层牌号 / coated grades  
 ■ 钎焊/金属陶瓷 / brazed/Cermet

尺寸单位 : mm  
Dimensions in mm

车槽

切断

铣槽

插削

仿形铣削

铰削



**Hartmetall Werkzeugfabrik**

**Paul HORN GmbH**

Unter dem Holz 33-35, D-72072 Tübingen  
Tel +49 (0)7071/70040, Fax +49 (0)7071/72893  
E-Mail info@phorn.de, www.phorn.de

**HORN USA, Inc.**

320 Premier Court, Suite 205, Franklin,  
TN 37067  
Tel +1 (888)818-HORN, Fax +1(615)771-4101  
E-Mail sales@hornusa.com, www.hornusa.com

**HORN CUTTING TOOLS Ltd.**

32 New Street, Ringwood, Hampshire,  
BH24 3AD, Tel +44 (0)1425/481 800  
Fax +44 (0)1425/481 888  
E-Mail info@phorn.co.uk, www.phorn.co.uk

**HORN Magyarország Kft.**

H-9027 Győr, Gesztenyefa u. 4  
Tel +36 96 55 05 31, Fax +36 96 55 05 32  
E-Mail technik@phorn.hu, www.phorn.hu

**HORN S.A.S**

665, av. Blaise Pascal, Zone Industrielle,  
77127 Lieusaint  
Tel +33 (0)1648859-58, Fax +33 (0)1648860-49  
E-Mail infos@horn.fr, www.horn.fr

**HORN (Shanghai) Trading Co. Ltd.**

Room 905, No. 518 Anyuan Road, P.R. of China  
Putuo District, Shanghai 200060  
上海市安远路518号905室 邮编 : 200060  
Tel : +86 21 52833505 ; 52833205  
Fax : +86 21 52832562  
E-Mail: info@phorn.cn, www.phorn.cn



**BLUECOMPETENCE**  
Alliance Member

Partner of the Engineering Industry  
Sustainability Initiative

**HORN-卓越于技术**  
HORN - EXCELLENCE IN TECHNOLOGY



INFO13.15CE, 05/2016, Printed in China